



ITALIANO



PELLERI

Since 1977

OFFICINA MECCANICA



IL PARCO MACCHINE

Lavorazioni meccaniche
di precisione

Schede tecniche





Fresa Mod.PX120

| | |
|---------------|------|
| Altezza "Z" | 2500 |
| Larghezza "Y" | 1200 |
| Lunghezza "X" | 6000 |

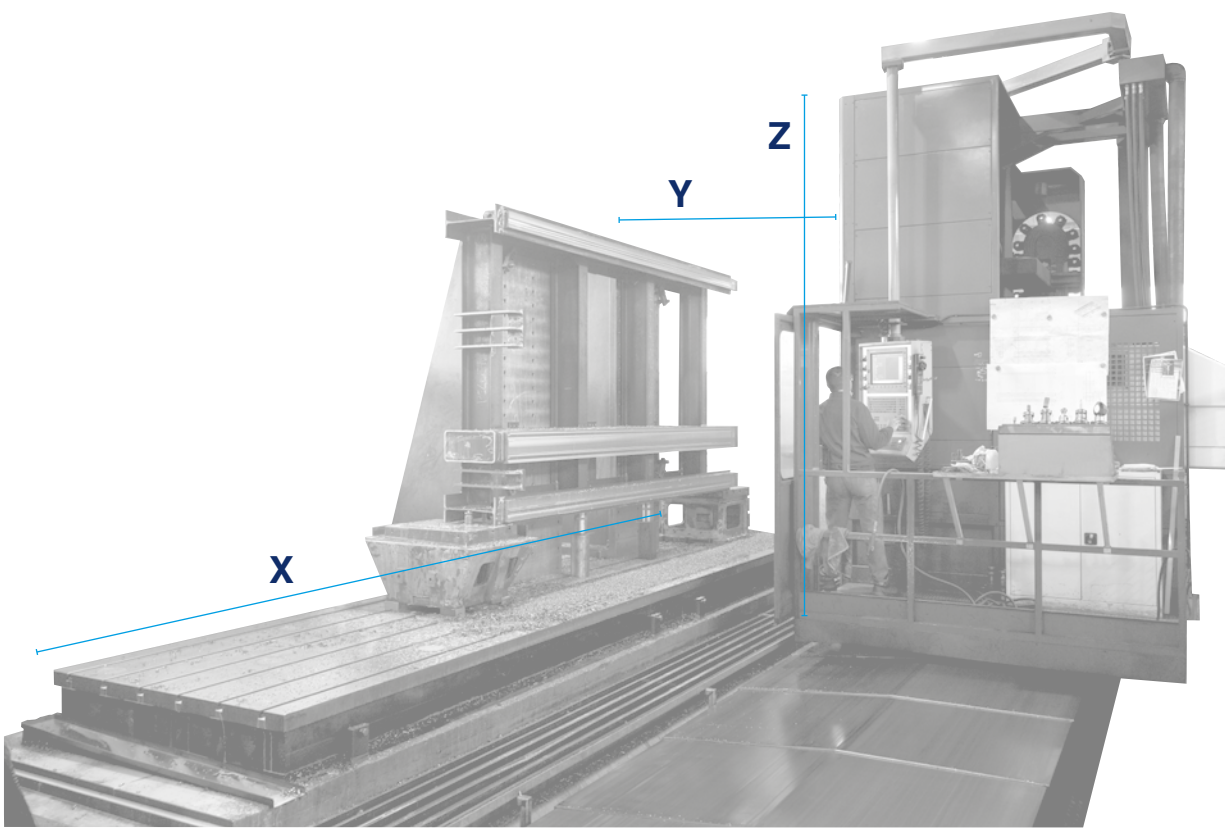





Fresa Mod. T314

| | |
|---------------|------|
| Altezza "Z" | 1900 |
| Larghezza "Y" | 1200 |
| Lunghezza "X" | 3500 |

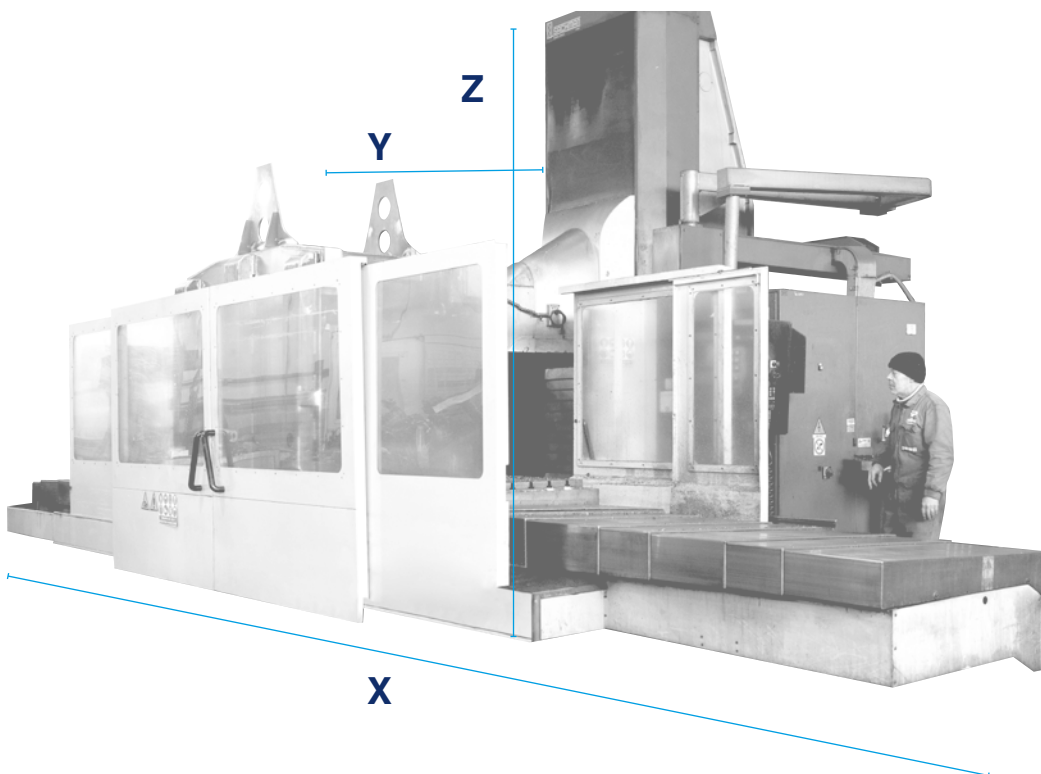





Fresa Mod.T10GP

| | |
|---------------|------|
| Altezza "Z" | 900 |
| Larghezza "Y" | 1000 |
| Lunghezza "X" | 2000 |

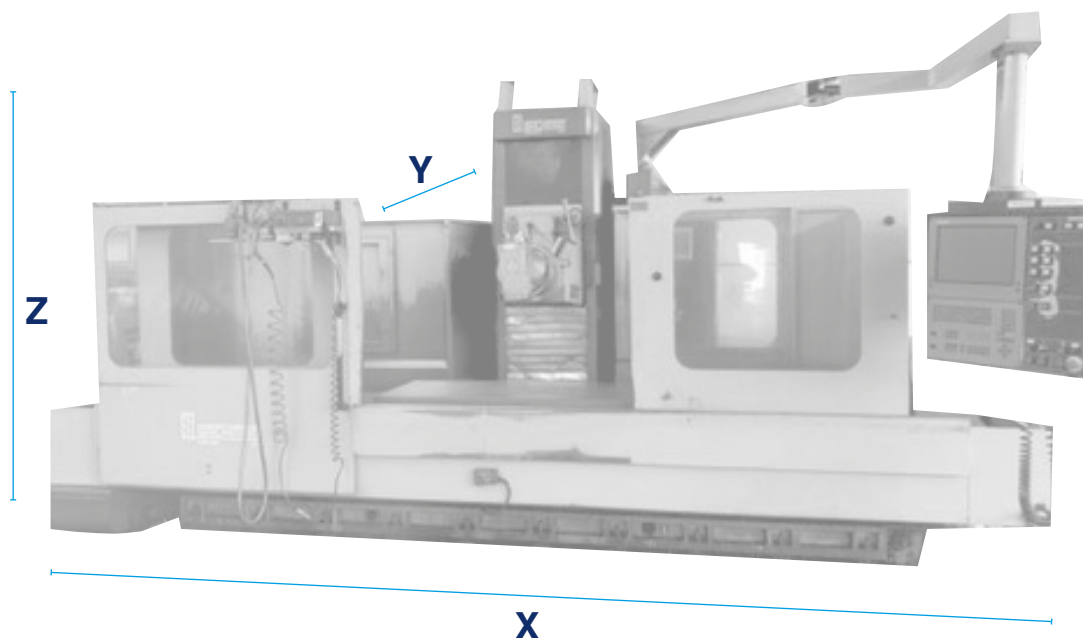

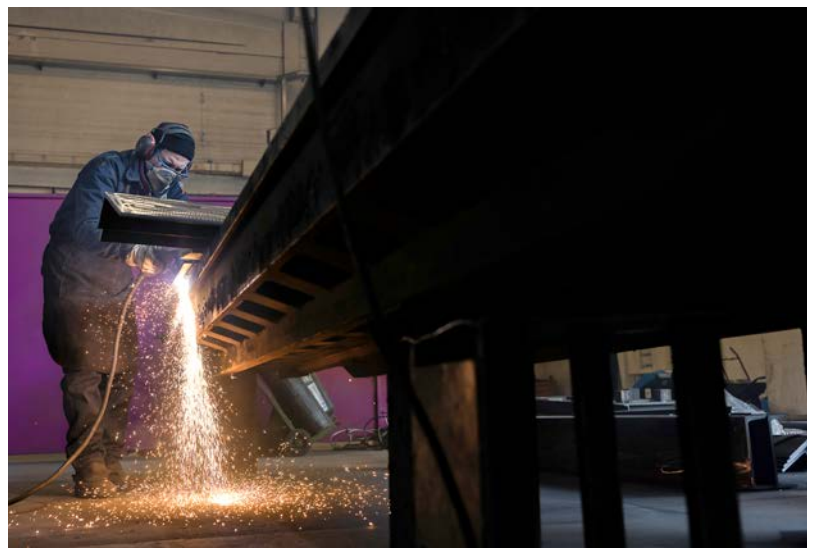
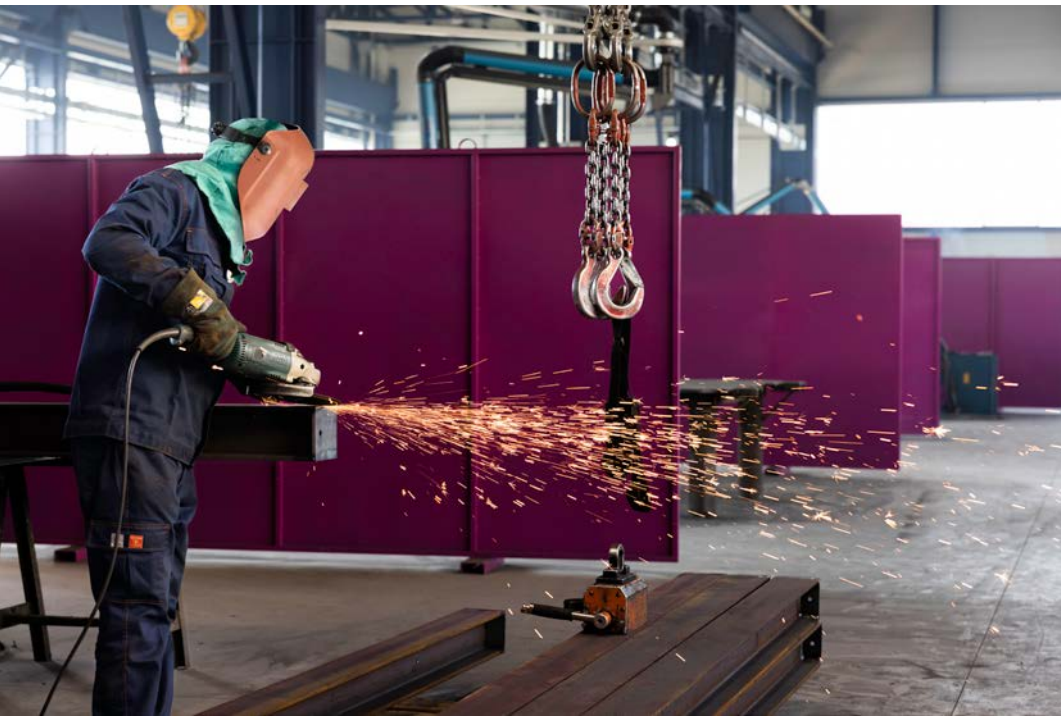



il parco macchine include:

| | |
|-----|---|
| N.8 | Saldatrici Kemppi |
| N.1 | Posizionatore A Tavola Mod.Pta 1200 |
| N.1 | Cesoia Cbc Taglio Sp.20 Mm |
| N.2 | Taglio Al Plasma Manuale |
| N.1 | Segatrice Imet Taglio Massimo D.250 Mm |
| N.1 | Seghetto A Nastro Fento Taglio Massimo D.500 Mm |
| N.1 | Pressa Oleodinamica Mt400 |
| N.1 | Pressa Piegatrice Utile 3000 Sp.6 |
| N.1 | Punzonatrice |
| N.1 | Trapano Radiale D.100 |
| N.1 | Trapano Colonna |
| N.1 | Tornio Utile D.300 Lungh. 1500 |
| N.3 | Carroponti Da 10 Ton |
| N.1 | Carroponte Da 30 Ton. |
| N.1 | Carroponte Da 16 Ton |
| N.1 | Carroponte Da 3,2 Ton. |



www.meccanicapelleri.it

Dove Siamo

Via Chico Mendez, 5
25030 Erbusco (BS)

Contatti

+39 030 772 2992
info@pelleri.it