



DEUTSCH



PELLERI

Since 1977

OFFICINA MECCANICA



UNSERE MASCHINEN

Mechanische
Präzisionsbearbeitungen

Datenblatt





Mod.PX120 Fräszentrum

Arbeitshöhe "Z"	2500
Breite "Y"	1200
Länge "X"	6000

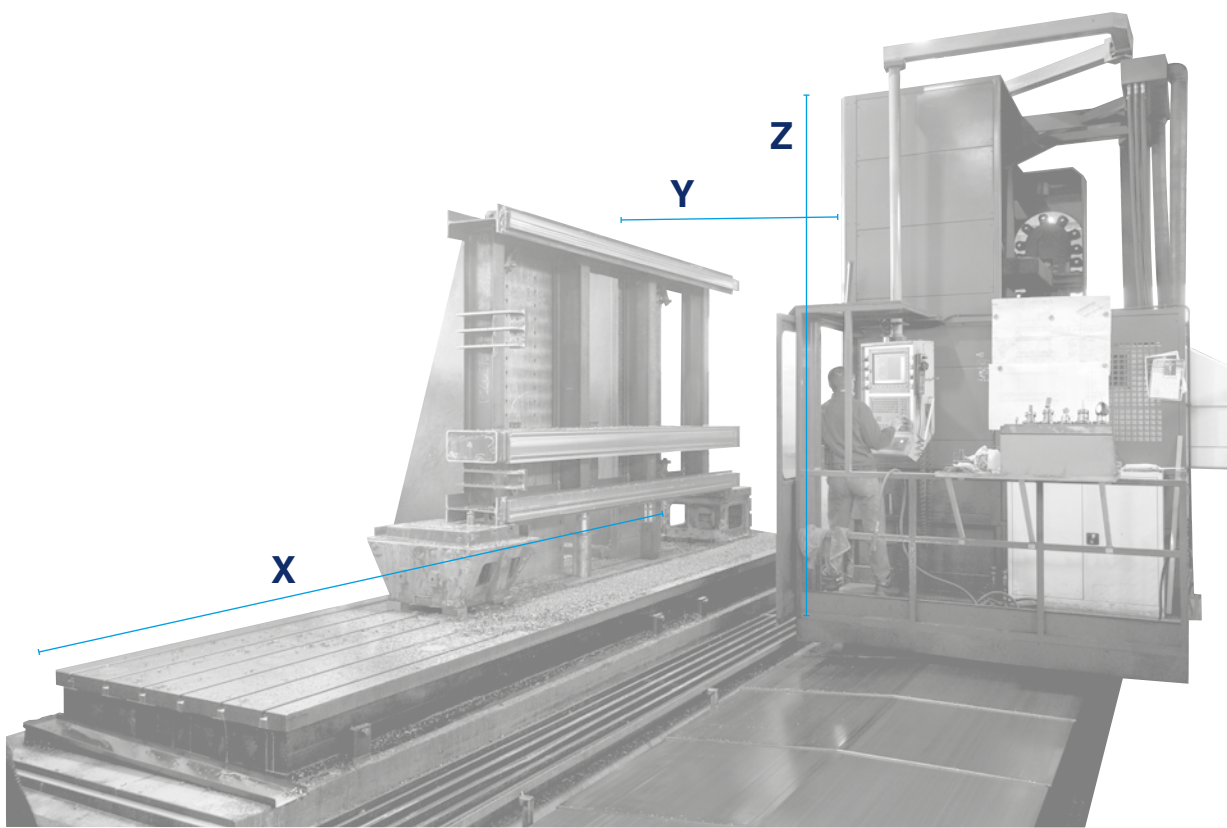





Mod. T314 Fräszentrum

Arbeitshöhe "Z"	1900
Breite "Y"	1200
Länge "X"	3500

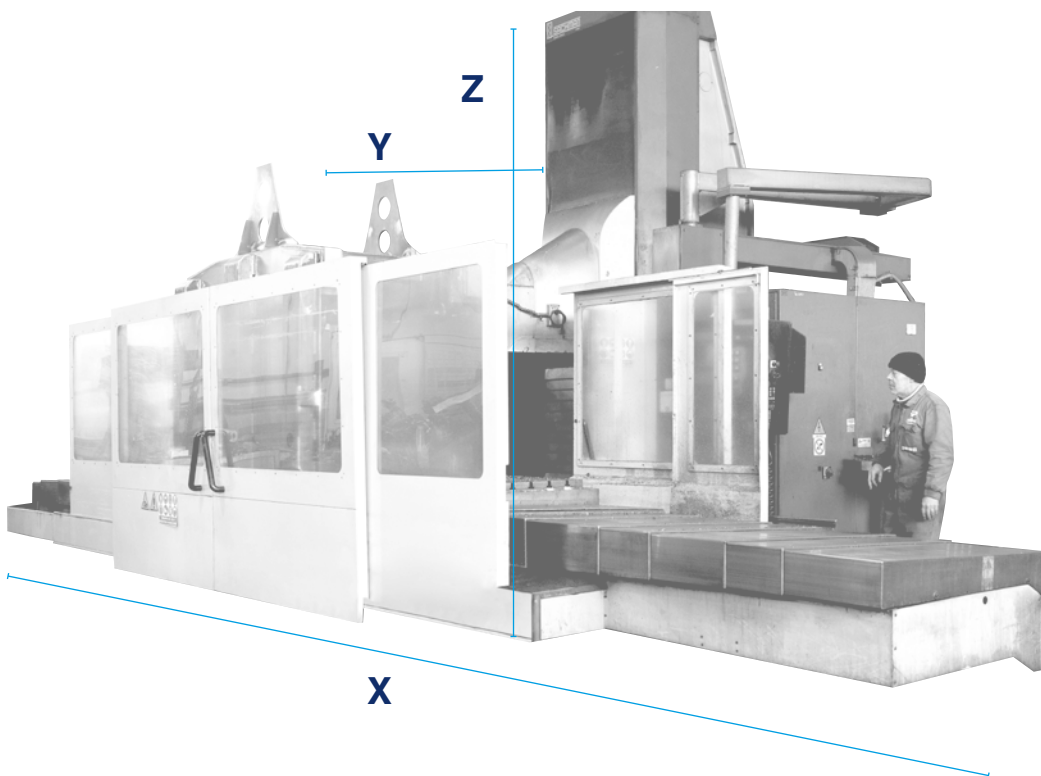





Mod.T10GP Milling Centre

Arbeitshöhe "Z"	900
Breite "Y"	1000
Länge "X"	2000

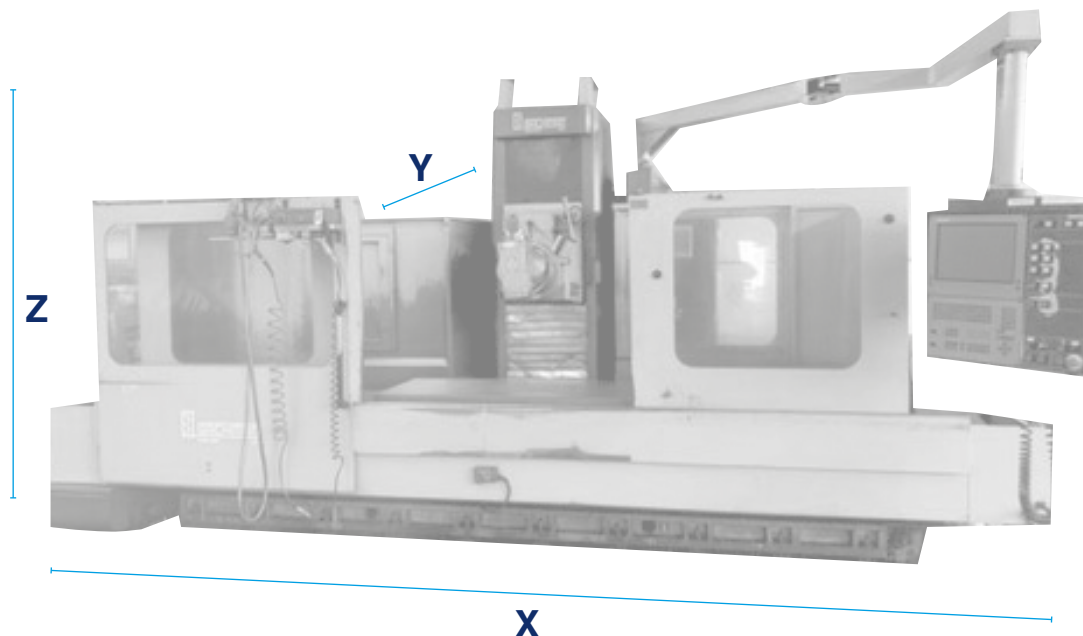

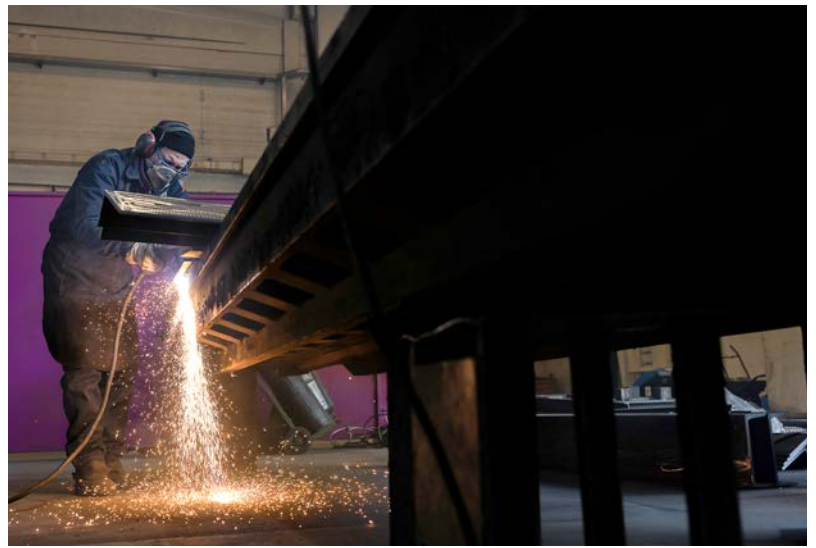
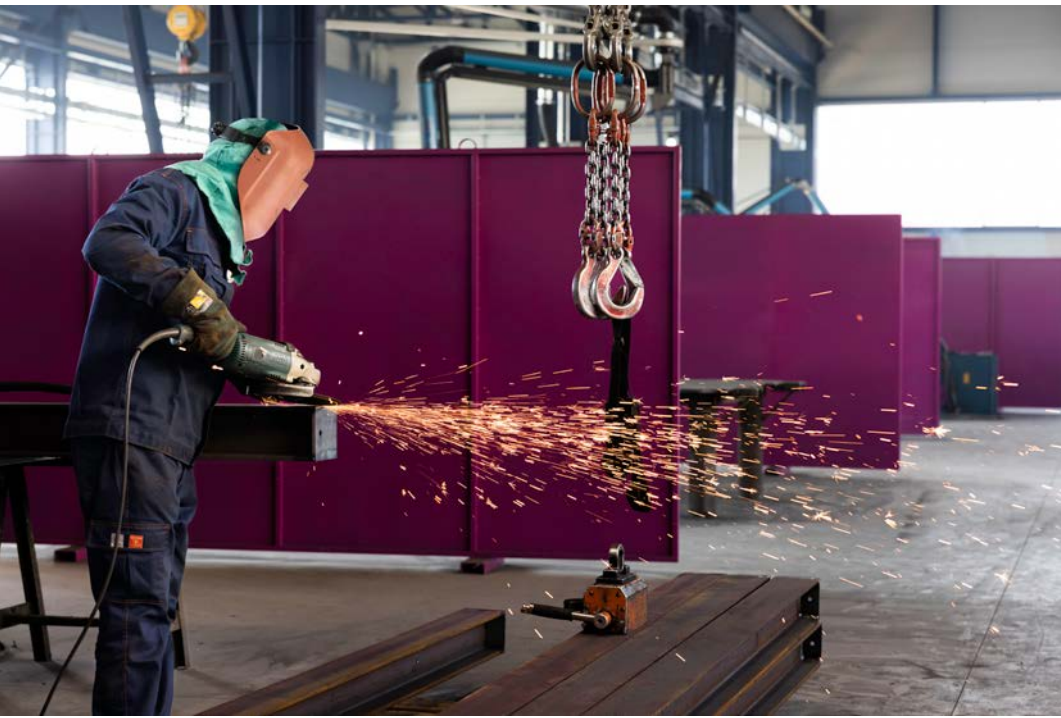



unsere präzisionsmaschinen umfassen:

No.8	Kemppi Schweißmaschinen
No.1	Drehtischpositionierer Mod. Pta 1200
No.1	CBC Slitter Scherendicke 20 mm
No.2	manuelle Plasmastrahl-Schneidemaschinen
No.1	Imet Sägemaschine Maximale Scherung D.250 mm
No.1	Fento Riemengetriebene Bügelsäge Maximale Scherung D.500 mm
No.1	Hydraulische Presse Nr. 1 Mt400
No.1	Abkantpresse 3000 max. Dicke 6
No.1	Stanzmaschine
No.1	Radialbohrmaschine D.100
No.1	Säulenbohrmaschine
No.1	Drehmaschine max. D.300 Länge1500
No.3	10-Tonnen-Laufkräne
No.1	30-Tonnen-Laufkräne
No.1	16-Tonnen-Laufkräne
No.1	3,2-Tonnen-Brückenkrane



www.meccanicapelleri.it

Wo wir sind

Via Chico Mendez, 5
25030 Erbusco
Brescia - Italy

Kontakte

+39 030 772 2992
info@pelleri.it